

PRODUCT DATA SHEET

DIMENSIONS IN mm

© 2005

<b>SAP Part No.</b> A6E62100084	<b>Title</b>  68 LITRE CO2 SEAMLESS CYLINDER (WORTHINGTON)	<b>Issue</b>	<b>Description</b>	<b>Date</b>
<b>Old Part No.</b> P30056075		1	ISSUED	14.07.05
<b>Data Sheet No.</b> 01-1196-01				

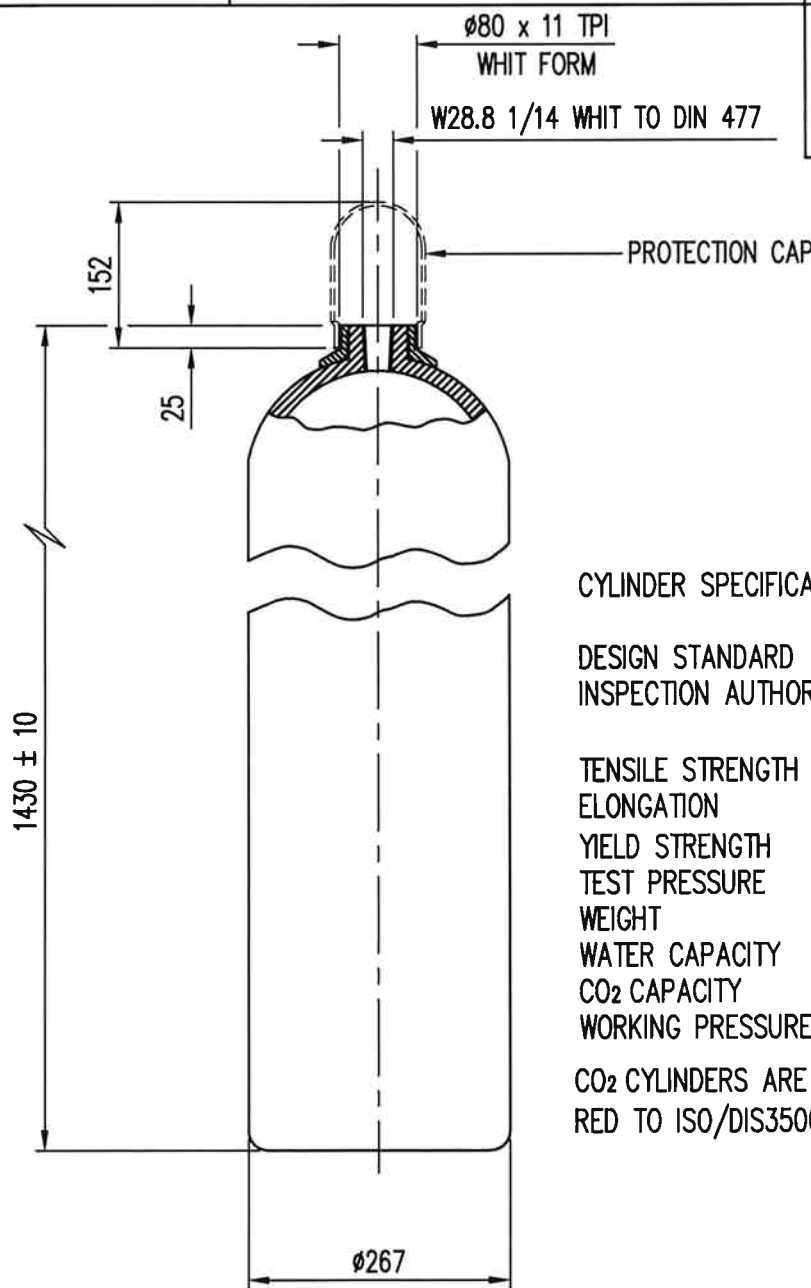

TPED	
FLUID GROUP:	2

**CYLINDER SPECIFICATION :-**

- DESIGN STANDARD - BS EN 1964 PART 1
- INSPECTION AUTHORITY - LLOYDS REGISTER OF SHIPPING
- TENSILE STRENGTH - 1120 N/mm<sup>2</sup> MIN
- ELONGATION - 12%
- YIELD STRENGTH - 990 N/mm<sup>2</sup> MIN
- TEST PRESSURE - 250 bar
- WEIGHT - 58.8 kg
- WATER CAPACITY - 68 litres
- CO<sub>2</sub> CAPACITY - 45.5 kg MAX
- WORKING PRESSURE - 166 bar

CO<sub>2</sub> CYLINDERS ARE PROVIDED PAINTED RED TO ISO/DIS3500

NOTE - THIS CYLINDER TYPE SUPPLIED MID-2005 ONWARDS.

\$\$ = Latest Issue of Data Sht.

<b>Data Sheet No.</b> 01-1196-01	<b>Sheet 1</b> of 3
-------------------------------------	------------------------

Siemens plc  
Siemens House  
Oldbury  
Bracknell  
Berkshire RG12 8FZ  
Company Reg. No. GB0007278217

Building Technologies  
Hawthorne Road  
Staines, Middlesex  
TW18 3AY  
Tel: 01784 461616  
Fax: 01784 464646

PRODUCT DATA SHEET

DIMENSIONS IN mm

© 2005

<b>SAP Part No.</b> A6E62100084	<b>Title</b>  68 LITRE CO2 SEAMLESS CYLINDER (WORTHINGTON)	<b>Issue</b>	<b>Description</b>	<b>Date</b>
<b>Old Part No.</b> P30056075		1	ISSUED	14.07.05
<b>Data Sheet No.</b> 01-1196-01				

INSTALLATION DETAILS

**ASSEMBLY OPTIONS**  
 APPLY PTFE TAPE TO VALVE THREAD & ASSEMBLE VALVE AND SYPHON TUBE ASSEMBLY INTO CYLINDER, TORQUE TIGHTEN TO 150 - 200Nm

TPED  
 FLUID GROUP: 2  

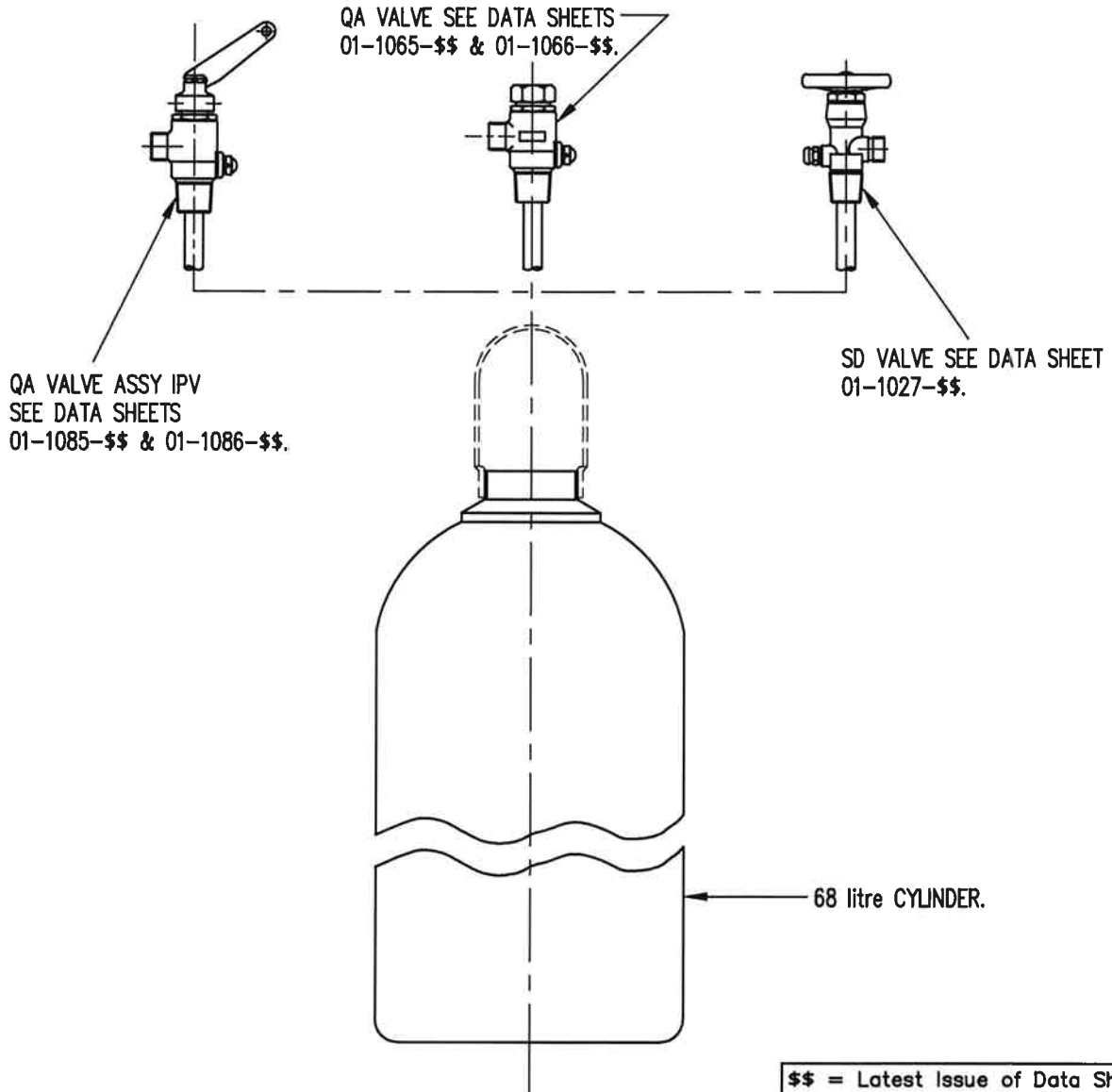

\$\$ = Latest Issue of Data Sht.

<b>Data Sheet No.</b> 01-1196-01	<b>Sheet 2</b> of 3
-------------------------------------	------------------------

Siemens plc  
 Siemens House  
 Oldbury  
 Bracknell  
 Berkshire RG12 8FZ  
 Company Reg. No. GB0007278217

Building Technologies  
 Hawthorne Road  
 Staines, Middlesex  
 TW18 3AY  
 Tel: 01784 461616  
 Fax: 01784 464646

PRODUCT DATA SHEET

DIMENSIONS IN mm © 2005

SAP Part No. <b>A6E62100084</b>	Title  <b>68 LITRE CO2 SEAMLESS CYLINDER (WORTHINGTON)</b>	Issue	Description	Date
Old Part No. <b>P30056075</b>		<b>1</b>	<b>ISSUED</b>	<b>14.07.05</b>
Data Sheet No. <b>01-1196-01</b>				

TPED  
 FLUID GROUP: 2  

MAINTENANCE

MAINTAIN IN ACCORDANCE WITH BS EN 1968

WARNINGS

DO NOT REMOVE CYLINDER BUNG UNTIL REQUIRED.

PROTECT FROM IMPACT – ANY CYLINDER SHOWING SIGNS OF IMPACT MUST NOT BE USED.

DO NOT MODIFY THIS PART IN ANY WAY.

DO NOT ATTEMPT TO USE THIS PRODUCT FOR ANY OTHER PURPOSE OTHER THAN AS A PART OF A CO2 FIXED FIRE EXTINGUISHING SYSTEM.

INSPECT FOR CORROSION OR DAMAGE BEFORE USE.

**\$\$ = Latest Issue of Data Sht.**

Data Sheet No. <b>01-1196-01</b>	Sheet 3 of 3
-------------------------------------	-----------------